

NOMENCLATURE

C=COMMERCIAL SERIES
M=MACHINE SERIES
A=ALLOY SERIES

M=MALE THREAD R.H.
B=MALE THREAD L.H.
W=FEMALE THREAD R.H.
G=FEMALE THREAD L.H.

ADULTS=RIGHT HAND
KIDS=LEFT HAND

LEFT HAND
FEMALE

METRIC
GROOVE
(R.H. & L.H.)

GROOVE

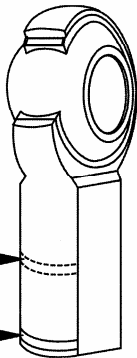

PRESENTS A,B,C's OF SPHERICAL ROD ENDS

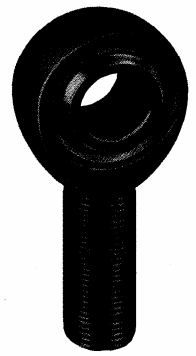

The traditional ball and roller bearings used by industry are anti-friction bearings designed to reduce friction and provide support in all kinds of rotating assemblies. Aurora industrial rod end and spherical bearings, in contrast, are friction-type bearings designed to provide more precise control, greater reliability, and greater wear resistance in oscillating assemblies. They are used in some slowly rotating applications, but their design characteristics are best utilized in back-and-forth, oscillating movements. Aurora rod end bearings are self-aligning. They have the ability to *oscillate radially* and *misalign axially*, qualities which permit sophisticated mechanisms to operate efficiently under conditions of extreme cycling, vibration, stress, load, speed and temperature.

Nomenclature of Aurora rod end bearings is relatively simple to understand. The first letter identifies the construction and material used in the bearing. There is a wide variety of standard Aurora rod end series. The three most widely used series are C, Commercial Grade, least expensive, M, Machine Grade, medium-priced, and A, Alloy Grade, Premium-priced materials. There are many other standard series as well; all are construction and material variations of the first three series. The HB series is a specially designed ball bearing unit.

The second letter in Aurora rod end nomenclature indicates the type of threads. The letter M, or Man, means Male external right-hand threads. B, or Boy, means Male external left-hand threads. W, or Woman, means Female internal right-hand threads. G, or girl, means Female internal left-hand threads. Just remember that the adults, M, Man and W, Woman are always right and that the kids, B, Boy and G, Girl are always left.

Right-hand and left-hand indicate the slant of the threads. Male right-hand threads slant upward to the right, left-hand threads upward to the left. Aurora CG and MG Series female rod ends; which have internal left-hand threads, have a circular groove near the bottom of the shank to differentiate them from the CW and MW Series female rod ends with internal right-hand threads.

The number after the grade and thread letters in Aurora rod end nomenclature denotes the bore diameter in sixteenths of an inch. Number 3, for example, means three-sixteenths inch; number 20 is twenty-sixteenths or an inch and a quarter. Metric bore diameters are in millimeters. Metric female rod ends have a circular groove in the middle of the shank to differentiate them from inch-series female rod ends.

NUMBERS = 16TH OF INCH

3 = 3/16"

20 = 1-1/4"

SUFFIXES

Z = GREASE ZERK

S = THREADED STUD

T = TEFLON LINER

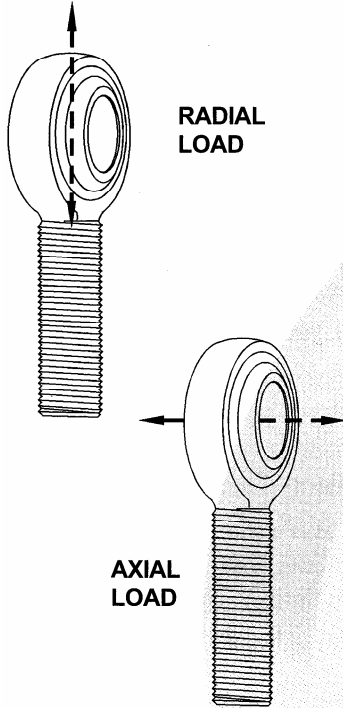

**ROD END RADIAL STATIC
LOAD CAPACITY = LOAD
TO BREAK BODY**

**RECOMMENDED RADIAL
OPERATING LOAD = 35%
RADIAL STATIC RATING**

**RECOMMENDED AXIAL
STATIC LOAD:
2 PIECE ROD END 15%
3 PIECE ROD END 10%
OF RADIAL STATIC RATING**

SPHERICAL BEARING LOADS

**RECOMMENDED RADIAL
OPERATING LOAD: 40% OF
RADIAL STATIC RATING**

**RECOMMENDED AXIAL
OPERATING LOAD: 20% OF
RADIAL STATIC RATING**

**STANDARD BORE
TOLERANCES**

C = +.0025 M = +.0015
 -.0005 -.0005

**SPECIAL BORE
TOLERANCES**

±.0000
-.0005

Standard accessories and modifications are identified by suffixes after the bore number. The letter T indicates the steel race has a PTFE liner, a woven fabric chemically bonded to the inner diameter of the race. A PTFE liner provides permanent lubrication and tight internal fit of the ball to the race, sometimes known as zero backlash or preloaded fit. Also available is a composite PTFE liner in our economical V series, designated by the prefix V. Aurora Bearing also produces a PTFE liner fully qualified to MIL-B-81820.

The letter Z means the rod end has a Zerk-type grease fitting, which is inserted in the shank of female bearings, or in the head of male bearings. F means a Flush-type grease fitting has been inserted in the bearing. The letter S indicates a right-hand threaded stud is affixed to the ball, a feature which provides easier installation for the user and permits greater misalignment of the bearing in a small space.

The Operating Load Capacity of Aurora rod ends is based on Ultimate Radial Static Load Rating, in simple terms, the number of pounds of pull necessary to break the rod end body. Operating Load is recommended at 35 percent of Ultimate Radial Static Load for slowly oscillating applications, 10 percent of Ultimate Radial Static Load for full rotation assemblies up to 100 rpm. Axial Static Load Capacity is recommended at 15 percent of Ultimate Radial Static Load for Aurora two-piece rod ends, 10 percent for three-piece rod ends. For PTFE-lined, heavy-duty shank units and studded units, consult with Aurora Engineering Department.

A rod end bearing's ability to misalign is measured by the degree of angle the ball can accommodate without interference. The misalignment angle is dependent upon the shaft-mounting procedure and the ball and body width.

Aurora makes many standard spherical bearing series, such as COM, meaning Commercial, HCOM, Heavy Duty Commercial, MIB, Machine Insert Bearing and AIB, Alloy Insert Bearing. They are identified by the letters and bore numbers. PTFE liners are available on all spherical bearings.

Maximum Radial Static Load Capacity of Aurora spherical bearings is based on a permanent set in the race of two-tenths of 1 percent of the ball diameter. Axial Load is recommended at 20 percent of the Radial Static Load, when the load-bearing surfaces are properly contained by the housing. Operating Load is recommended at 40 percent of Radial Static Load.

All production stages at Aurora Bearing Company undergo strict quality control inspection, from incoming materials through processing to final shipment. Our quality system is based on a simple philosophy - Do It Right The First Time. Today, we use many tools such as SPC control charting, parts analysis, flow charting, statistical sampling, gage variation studies, team problem solving, vendor quality rating, and many more.

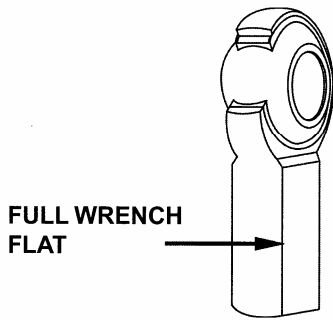

The manufacturing of Aurora Bearings starts with the balls. Aurora C Series rod ends, which use the body as the race, have sintered steel balls. Aurora sintered steel balls have identifying lines on the face, or ends, of the ball. Other Series rod ends have solid steel balls that are through hardened. The balls are made to a standard bore tolerance of three-thousandths of an inch for C Series rod ends, two-thousandths of an inch for other standard bearings. Bore tolerances can be maintained up to five ten-thousandths of an inch for special user requirements.

Aurora races are produced on screw machines, then drilled for oil or grease lubrication, tumbled, plated for corrosion resistance, and dipped in chromate for added protection.

Aurora rod end bodies are under careful quality control beginning with the screw machine operation, and continuing through every stage of construction. Aurora rod end bodies are plated, and dipped in chromate or dichromate. The plating and dipping of bodies and races is a standard Aurora construction feature that increases corrosion protection 80 to 100 percent over regularly-plated bearings. Special plating is applied on S Series rod ends for use in excessively corrosive atmospheres. All Aurora rod ends have precision UNF, UNJF, or ISO metric threads. Female rod ends are machined to incorporate full-length wrench flats for easier assembly by the user. Aurora uses only full swage-type assembly, a procedure which assures conformance of parts and careful compliance with specifications. The ball is always precision fit after assembly to provide closely controlled radial clearance.

Aurora C Series economy rod ends are of a two-piece design consisting of a low carbon steel, 75,000 PSI body and a heat-treated, sintered steel ball, with the body serving as the race. By eliminating a separate race, a smaller bore is required in the rod head, providing greater head strength. The ball is inserted in the body, which is swaged around the ball. C Series bearings offer precision service at lower cost for operations requiring strong, economical bearings. They are available in eight bore sizes from 3 to 12, male and female.

Aurora M Series rod ends have a three-piece construction for applications requiring high precision and wear resistance. A one piece, low carbon steel race is swaged around a through-hardened steel ball, forming a spherical bearing which is then staked into a low carbon steel 75,000 PSI body. The standard bore sizes range from 2 to 32, male and female. Male sizes 6 through 12 are available with a lubrication hole up the center of the shank as an optional feature. If a solid shank is required, use the suffix Y.

Aurora A Series rod ends are also of a three-piece construction. They have a heat-treated alloy steel, one-piece race swaged around a through hardened alloy steel ball. This is staked in an alloy steel 175,000 PSI body. The A Series bearings are for applications requiring the ultimate in strength, precision, and wear resistance. They are available in standard bore sizes from 3 to 32, male and female. Both M and A Series rod ends frequently are used to replace other makes of bearings which have failed to maintain specified work requirements.

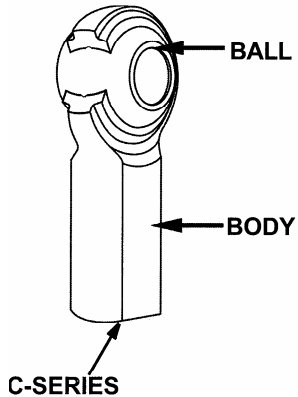

C-SERIES
2 PIECE CONSTRUCTION
3/16 TO 3/4 INCH BORES

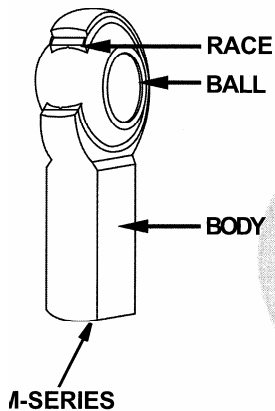

M-SERIES
3 PIECE CONSTRUCTION
1/8 TO 2 INCH BORES

A-SERIES
3 PIECE CONSTRUCTION
ALL ALLOY MATERIAL
1/16 TO 2 INCH BORES

“-T” SUFFIX

**3 PIECE CONSTRUCTION
3/16 TO 2 INCH BORES**

K-SERIES

**3 PIECE CONSTRUCTION
ALLOY HEAT TREAT RACE
3/16 TO 2 INCH BORES**

X-SERIES

**3 PIECE CONSTRUCTION
HEAVY DUTY
MALE THREADS
1/8 TO 1-1/2 INCH BORES**

SPHERICAL BEARINGS

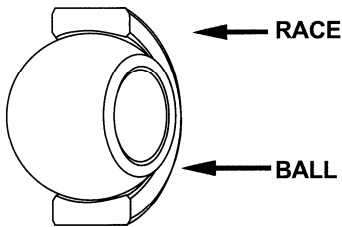

**COM-SERIES
HCOM-SERIES
MIB-SERIES
AIB-SERIES
SIB-SERIES**

1/8 TO 2 INCH BORES



Aurora “-T” Suffix rod ends have three-piece construction with a PTFE-lined race, the finest in pre-lubed, friction-type bearings. They are offered in bore sizes 3 through 32, male and female, and are available in all three-piece rod end variants.

K Series rod ends have the M Series ball and body with an A Series heat-treated alloy steel race. They are especially reliable for jobs requiring greater wear resistance under high vibration or high frequency reversing loads. K Series rod ends are available in bore sizes from 3 to 32, male and female.

Aurora X Series rod ends feature an extra heavy duty shank and a larger thread diameter to provide greater load carrying capacity. They are available only with male external threads in bore sizes from 2 through 24, and either low-carbon, or alloy steel bodies.

Where corrosion is a problem, Aurora offers stainless steel parts in both two and three piece designs, with or without PTFE liners. They are available in most bore sizes, male and female. Aurora HB Series rod ends are self-aligning ball bearings with ductile iron housings. They are designed for high-rotation operations and are available in three bore sizes: 8, 10, and 12.

The many Aurora spherical bearing series, made for insertion into user housings, have a one-piece, oil-coated, steel race swaged around a through-hardened ball. The spherical bearings are available in standard bore sizes from 2 to 32. Larger sizes can be made to order. They may be ordered with or without PTFE liners or heat-treated alloy, or stainless steel races.

Aurora Bearing Company has developed and received approval of a PTFE Liner System to MIL-B-81820, spherical bearings to MS-14101 through MS-14104, rod ends to MIL-B-81935, and PTFE lined bushings to MIL-B-81934.

Virtually everywhere you look, there are products which use Aurora bearings, or which would function more precisely and durably if they were using Aurora bearings! Aurora is highly experienced in designing and manufacturing rod end and spherical bearings for highly unique requirements in new and redesigned equipment. The variety of unusual bearings made by Aurora includes rod ends that are bent to clear other components, bearings with special materials such as high nickel cobalt steel, to withstand turbine temperatures in excess of 14 hundred degrees Fahrenheit! Bearings in virtually any shape, size, and material, according to the dictates of customer engineering needs! Whenever precision industrial rod end and spherical bearings are involved, you should call on Aurora Bearing Company. The people who devote all their time to precision rod end and spherical bearings. The Motion-Transfer Specialists.